

PART A

(Q1 to Q6: All questions are compulsory; Each Question carries 3 marks)

1. Define (a) Hund's rule; (b) Pauli's (Exclusion) Principle; (c) Aufbau principle. (1+1+1)
2. Explain various types of quantum numbers.
3. Is O₂⁻ diamagnetic or paramagnetic? Justify your answer using molecular orbital diagram.
4. (a) What is polarizing power and polarizability? (b) Explain Fajan's rules. (1.5+1.5)
5. Define with at least one application of (i) Common Ion Effect; (ii) Solubility Product constant (K_{sp}). (1.5+1.5)
6. Given that K_{sp} (AgCl) is 1.7 × 10⁻¹⁰ M². Predict whether precipitate of AgCl would form if 25 mL of 0.01 M AgNO₃ solution is mixed with 25 mL of 0.0005 M aqueous NaCl solution.

PART B

(Q7 to Q11: Attempt any FIVE questions; Each Question carries 4 marks)

7. According to Bohr's Atomic Theory, derive the formulae for $\bar{\nu}$.
8. If the z⁺ and z⁻ are the charges on the positive and negative ions respectively, e is the charge of the electron, N_o is the avagadro's number, A is the Madelung constant of the crystal, r_o is the equilibrium distance; starting from the columbic energy between two ions, derive an equation (*Born-Landé*) for lattice energy of the crystal.
9. (a) Using the established equilibrium of a weak acid (HA) in water, derive the relationship between pH and pK_a (Henderson-Hasselbalch equation). (b) Derive the formula of K_{sp} for Pb(IO₃)₂ and AlCl₃ in water. (2+2)
10. (a) Define the following Acid-Base concepts with examples: (i) Bronsted-Lowry's concept; (ii) solvent system theory. (2+2)
11. (a) Write the chemical reactions occurring during chromyl chloride test. (b) Draw the Born-Haber cycle in chart form. (2+2)
12. (a) Define Hammett acidity function. Name any four superacids with their H_o value. (b) Draw the molecular orbital diagram for N₂ molecule. (2+2)

PART C

(Answer ANY ONE of the following questions; Q13 or Q14)

13. (a) Define lattice energy. Calculate lattice energy (U) of CsCl using following data:

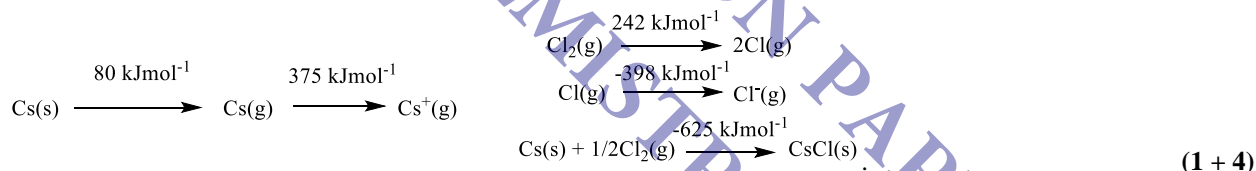

- (a) What is shielding effect? Explain effective nuclear charge and calculate it for the last valence electron of Nitrogen and Zinc. (3)
- (b) (i) Write an expression for the velocity of an electron revolving in the nth orbit of H-atom and H-like species. (ii) Draw the chart for cationic group separation in qualitative analysis. (2 + 2)

(OR)

14. Answer the following:

- (a) Explain the various spectral lines identified from the atomic spectra of hydrogen atom. (4)
- (b) (a) Write at least four postulates of Valence Shell Electron Pair Repulsion (VSEPR) theory. (b) Discuss the structure of carbonate (CO₃²⁻) and SF₆ using valence bond theory of bonding. (2 + 2)
- (c) When a mole of crystalline NaCl is prepared from 1 mole of Na(s) and half a mole of Cl₂(g), 410 kJ of heat is produced. The heat of dissociation of Cl₂(g) is 242 kJmol⁻¹ and the electron affinity of Cl(g) is 368 kJmol⁻¹. The sublimation energy of Na(s) is 109 kJmol⁻¹ and the ionization energy of Na(g) is 495 kJmol⁻¹. Calculate the lattice energy of NaCl from this data. (4)



CENTRAL UNIVERSITY OF RAJASTHAN

School of Chemical Sciences and Pharmacy

Department of Chemistry

Integrated M. Sc. (Sem.- III): End of Semester Examination

Course: ICHT - 301 (Physical Chemistry - I)

Maximum Marks: 50

Date: November 29, 2017

Time: 2.00 - 5.00 PM (3 hrs.)

$\log 2 = 0.3010$, $\log 3 = 0.4771$, $\log 5 = 0.6991$ and $\log 7 = 0.8451$; $R = 8.3145 \text{ J mol}^{-1} \text{ K}^{-1}$

(A) Questions 1-6 are compulsory. Attempt **any five** from Questions 7-12. Attempt **any one** from Question 13-14.

(B) Symbols have usual meaning. Calculator is **not** allowed.

1. Solve the following [3]

(a) $3^{2x+7} = 7^{3x+2} \cdot 2^{x+1}$

(b) Evaluate $\int \frac{x^2-4}{x+1} dx$

2. Solve the following [3]

(a) Find $\log \sqrt{\left(3\frac{3}{8}\right)}$

(b) Find derivative of $\frac{x}{\sin 3x}$

3. What are the units of van der Waals constant **a** and **b**? Do these constants depend upon temperature of the gas? [1+1+1=3]

4. What is the unit of Viscosity? What is the effect of temperature on viscosity for a particular solvent? Between ethanol and di-ethylether which one is high viscous solvent? [1+1+1=3]

5. Calculate the standard enthalpy of formation of CaCO_3 at 298 K in kcal mol^{-1} from the following data: [3]

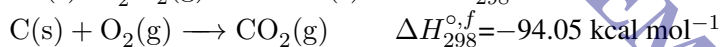
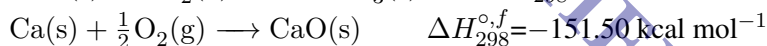
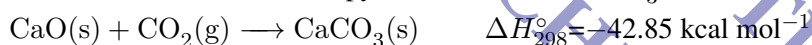

6. (a) What happens to the temperature of the system (increased/decreased) when an endothermic process takes place in an adiabatic container? Why? [1]

(b) For oxidation of iron, $4\text{Fe(s)} + 3\text{O}_2(\text{g}) \longrightarrow 2\text{Fe}_2\text{O}_3(\text{s})$; $\Delta H_{298}^\circ = -1490 \times 10^3 \text{ J mol}^{-1}$, the entropy change is $-549.4 \text{ JK}^{-1} \text{ mol}^{-1}$ at 298 K at constant pressure. In spite of negative entropy change of this reaction, why is the reaction spontaneous? [2]

7. If the density (Sp. gravity) written on 1 Ltr. bottle of 90 % conc.ⁿ H_3PO_4 is 1.8 g/ml at 21 °C then [4]

(a) Calculate normality of conc.ⁿ acid in bottle.

(b) Calculate volume of above conc.ⁿ acid required to prepare dilute H_3PO_4 solution having $\text{pH}=4.4771$ in 250 ml volumetric flask.

8. Sketch a phase diagram of Sulphur system. Comment on critical point, critical temperature and critical pressure with degree of freedom. [4]

9. (a) From the given value of **b** for a real gas, how would you calculate the molecular diameter of a molecule of a given real gas? [2]

(b) What do you understand by the term '**compressibility factor (Z)**' of a gas? How **Z** versus **P** (pressure) plots depends on temperature for a given real gas. [2]

10. Explain the Debye Interaction and London dispersion force. [2+2=4]

11. Using the Carnot cycle, prove that the entropy is a state function. (*Assume the system to be a perfect gas*) [4]
12. 1g of graphite is burnt in a bomb calorimeter in excess of oxygen at 298 K and 1 atmospheric pressure according to the equation $C(\text{graphite}) + O_2(g) \rightarrow CO_2(g)$. During the reaction, the temperature rises from 298 K to 299 K. If the heat capacity of the bomb calorimeter is 20.7 kJ K^{-1} , what is the molar enthalpy change for the above reaction at 298 K and 1 atm? [4]
-
13. (a) Derive Clausius-Clapeyron equation and find melting point of ice at 10 atm. (For 1 g of ice, $\Delta_{fus}H=333.6 \text{ J}$ and densities $\Delta_{fus}V=-0.09 \text{ cm}^3$) [4]
- (b) What is Capillary action? Derive the formula: $\gamma = \frac{1}{2}(h\rho g)$. Let's say the surface tension of butanol are x and y at temperature 300°C and 700°C respectively; which value of the surface tension will be higher? [1+2+1=4]
- (c) The standard enthalpy of formation of $H_2O(g)$ at 298 K is $-241.82 \text{ kJmol}^{-1}$. Estimate its value at 100°C given the following values of the molar heat capacities at constant pressure: $H_2O(g)$: $33.58 \text{ JK}^{-1}\text{mol}^{-1}$; $H_2(g)$: $28.84 \text{ JK}^{-1}\text{mol}^{-1}$; $O_2(g)$: $29.37 \text{ JK}^{-1}\text{mol}^{-1}$. Assume the heat capacities are independent of temperature T. [2]
- (d) Give expressions for Helmholtz Energy and Gibbs Free Energy. Explain their importance in thermodynamics in one sentence? [2]
14. (a) Sketch a phase diagram of solid-liquid equilibria system with one suitable example which shows in-congruent melting point. [4]
- (b) The critical constant of water are 647 K , $22.09 \times 10^3 \text{ kPa}$, $0.0566 \text{ dm}^3\text{mol}^{-1}$. Calculate the value of **a**, **b** and **R** and explain the abnormal value of **R**. [3+1=4]
- (c) When 0.02 mol of a perfect gas undergoes an adiabatic, reversible expansion at 25°C , the volume was changed from 0.04 L to 1 L. The molar heat capacity of the gas at constant volume is $16.63 \text{ JK}^{-1}\text{mol}^{-1}$ and so $c = 2$ (where $c = C_V/nR$). Calculate the (i) the final temperature, and (ii) the adiabatic work done. [4]

—◇—◇—◇—

PART-A

All questions are compulsory. Each question carries 3 marks

- How does the percent transmittance of a solution vary with (a) increasing concentration and (b) increasing path length? A solution of thickness 2 cm transmitted 40% incident light. Calculate the concentration of solution given that $\epsilon = 6000 \text{ dm}^3 \text{ mol}^{-1} \text{ cm}^{-1}$. **(1+2 marks)**
- A thermal analyst wanted to ascertain whether a given sample was MgO or MgCO_3 or MgC_2O_4 . He then subjected a 350.00 mg sample to a thermogravimetric analysis, for which the thermogram showed a loss of 182.00 mg and after increasing temperature no further mass change. Which of the three formulae above represent the compound present in the sample and give possible reaction? (Atomic mass of Mg: 24.305 Da).
- Which molecule absorbs at the longest wavelength in each group. (a) 1,3-hexadiene or 1,4-hexadiene and (b) (2E,5E)-2,5-heptadien-4-ol (A) or (2E,5E)-2,5-heptadien-4-one (B). Justify.

**(1.5+1.5 marks)**

- Diagram the fundamental modes of vibration of NO_2^+ and predict which modes will be infrared active and which will be Raman active.
- Find out the correct answer: (i) Systematic errors originate from (a) a ruler smashed at one end (b) a balance on a wobbly table (c) ignition of hygroscopic material in open atmosphere (d) (a), (b) and (c). (ii) In Gaussian curve, standard uncertainty (σ) fixes the data range in area of (a) 63.8 % (b) 68.3% (c) 95.7 % (d) 97.5 %. (iii) The legitimate measure of central tendency for nominal scale data distributions is (a) mean (b) median (c) mode (d) (a), (b) and (c). **(1+1+1 marks)**
- How systematic errors can be minimised? (Mention the name of methods only)
- (i) A series of 3 coloured glass plates of equal thickness are placed in a light beam. Each sheet absorbs one quarter of the light incident upon it. What is the intensity of the light transmitted by the third glass plate? (ii) In Infrared spectroscopy which frequency region is known as finger print region? **(2+1 marks)**
- (i) Define the term 'Chromatography'? (ii) Which of the following cannot be used as adsorbent in Column adsorption chromatography? (a) Magnesium oxide (b) Silica gel (c) Activated alumina (d) Potassium permanganate (iii) Chromatography cannot be used to purify volatile substances. (a) True or (b) False.

(1+1+1 marks)**PART-B**

Answer any six questions. Each question carries 4 marks

- (i) What are the common techniques used for detecting colorless spots in chromatographic technique? (ii) What information you get from the retardation factor value? (iii) What are the limitations of paper chromatography? **(1+2+1 marks)**
- Give a brief outlined procedure for the determination of chloride ion concentration in tap water by using potentiometry.
- Sketch a neat diagram of color wheel and describe briefly primary, secondary, tertiary and complementary colors.
- (i) How many significant figures are present in (a) π (22/7) (b) 10^4 ? (ii) Suppose an object is weighed for five times and the following values are obtained 0.1010 g, 0.1020 g, 0.1005 g, 0.1030 g, 0.1015 g. Calculate mean deviation and relative mean deviation of above values. **(1+3 marks)**
- (i) What are the factors that can affect TG curve? (ii) What are the physical/chemical phenomena causing changes in temperature in DTA? **(2+2 marks)**
- (i) Discuss any two factors that could lead to deviations from Beer's Law? **(2 marks)**
(ii) How can you verify Beer-Lambert's Law? **(2 marks)**
- Explain in detail how does ion exchange column chromatography works in (i) separation of lanthanides and (ii) softening of water. **(2+2 marks)**

(Turn over)

PART-C

Answer only one question (either **Q. No. 16** or **17**). Each question carries 12 marks

16. Answer the following questions

- (i) What are the various types of electronic transition do you expect for the following compounds and also mention whether transition is allowed or forbidden. (a) Cl_2 (b) methyl amine (c) anthracene (d) cyclohexane. **(1+1+1+1 marks)**
- (ii) Give a detailed procedure for the separation of two organic compounds benzyl alcohol and benzoic acid by using column chromatography (clearly mention type of adsorbent and eluant used for your study) **(4 marks)**
- (iii) (a) An aqueous solution of NaOH is slowly added to an aqueous mixture of HCl and oxalic acid. Sketch the variation in the conductance by addition of NaOH. **(2 marks)**
- (b) Proton exists in water has various cage structures (H_5O_2^+ , H_9O_4^+ , $\text{H}_{11}\text{O}_5^+$) explain how even it has high ionic mobility? **(2 marks)**

OR

17. Answer the following questions

- (i) Five isomeric compounds with the formula $\text{C}_5\text{H}_{10}\text{O}$ were analyzed by infrared spectroscopy. The fingerprint regions and the carbon-hydrogen stretch regions were not analyzed. Based on the given spectral information, for each of the following choose the structure from the structures (**Chart 1**) below which is consistent with the data. (a) a strong peak at 1710 cm^{-1} . (b) a strong, broad peak at 3430 cm^{-1} but no peak at $1650\text{-}1670\text{ cm}^{-1}$. (c) a strong peak at 3420 cm^{-1} and a weak peak at 1600 cm^{-1} . (d) a weak peak at 1660 cm^{-1} but no peak at $3300\text{-}3600\text{ cm}^{-1}$. (e) no peaks at $3300\text{-}3600\text{ cm}^{-1}$, $1650\text{-}1670\text{ cm}^{-1}$, $1700\text{-}1750\text{ cm}^{-1}$. **(5 marks)**

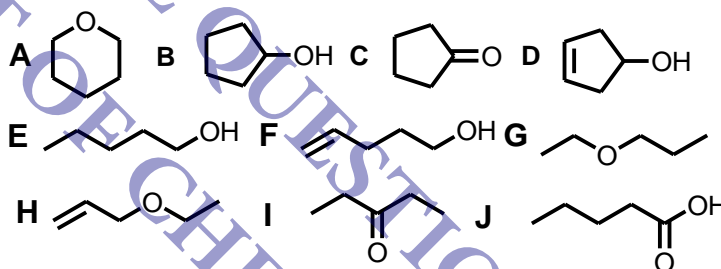

- (ii) Calculate a pooled estimate of the standard deviation for the following results of glucose concentrations in four months.

Time	Glucose concentration, mg/L						
Month 1	1108	1122	1075	1099	1115	1083	1100
Month 2	992	975	1022	1001	991	-	-
Month 3	788	805	779	822	800	-	-
Month 4	799	745	750	774	777	800	758

(5 marks)

- (iii) Give a brief outlined procedure for determination of unknown concentration of KMnO_4 by using Beer-Lambert's law? **(2 marks)**



CENTRAL UNIVERSITY OF RAJASTHAN

School of Chemical Sciences and Pharmacy

Department of Chemistry

Integrated M. Sc. (Sem.- V): End of Semester Examination

Course: ICHT - 503 (Physical Chemistry - II)

Maximum Marks: 50

December 07, 2017

Time: 2.00 - 5.00 PM (3 hrs.)

$\log 2 = 0.3010$, $\log 3 = 0.4771$, $\log 5 = 0.6991$ and $\log 7 = 0.8451$; $R = 8.3145 \text{ Jmol}^{-1}\text{K}^{-1}$

(A) Questions 1-6 are compulsory. Attempt **any five** from Questions 7-12. Attempt **any one** from Question 13-14.¹

(B) Symbols have usual meaning.

- (i) Write an example of autocatalytic reaction? (ii) Give a mechanism for the Cl atom catalyzed decomposition of stratosphere ozone? [2+1=3]
- What are the assumptions of Langmuir theory of adsorption? For Langmuir isotherm, show that at low pressure condition the fraction of surface coverage behaves as first order. [3]
- The EMF of the standard Weston cell written as $\text{Cd(Hg)}, \text{CdSO}_4 \cdot \frac{8}{3} \text{H}_2\text{O(s)} || \text{CdSO}_4(\text{sat.}), \text{Hg}_2\text{SO}_4(\text{s}), \text{Hg}$ in which the cell reaction is 1.0185 V at 25 °C
 $\text{Cd(Hg)} + \text{Hg}_2\text{SO}_4(\text{s}) + \frac{8}{3} \text{H}_2\text{O(l)} \longrightarrow \text{CdSO}_4 \cdot \frac{8}{3} \text{H}_2\text{O(s)} + \text{Hg(l)}$
Calculate ΔG° , ΔS° , and ΔH° for the cell reaction if $(\Delta E^\circ/\Delta T)_P$ for the cell is $5.00 \times 10^{-5} \text{ VK}^{-1}$. ($F = 96485 \text{ C mol}^{-1}$). [3]
- Explain theory of Unimolecular reactions using Lindemann Mechanism. [3]
- Prove that for an ideal gas, $(\partial V/\partial S)_P = nRT/(PC_P)$ [3]
- For the reaction $2 \text{A} + \text{B} \longrightarrow \text{C} + \text{D} + 2 \text{E}$, data for a run with $[\text{A}]_0 = 800 \text{ mmol/L}$ and $[\text{B}]_0 = 2.00 \text{ mmol/L}$ are:

t/ks	8	14	20	30	50	90
$[\text{B}]/[\text{B}]_0$	0.836	0.745	0.680	0.582	0.452	0.318

and data for a run with $[\text{A}]_0 = 600 \text{ mmol/L}$ and $[\text{B}]_0 = 2.00 \text{ mmol/L}$ are:

t/ks	8	20	50	90
$[\text{B}]/[\text{B}]_0$	0.901	0.787	0.593	0.453

Find the rate law and rate constant.

[3]

- (i) How can you classify monolayer versus multilayer formation by adsorption isotherm? (ii) Give a detailed procedure for obtaining v_{mono} by using BET theory? [2+2=4]
- Identify the type of catalysis (homogeneous or heterogeneous) and specify the catalysts used in the following reactions: (i) Hydrogenation of alkene by Wilkinson catalyst (ii) Haber process (iii) Contact process (iv) Suzuki C-C coupling reaction. [1+1+1+1=4]
- (a) Calculate the solubility product of AgBr in water at 25 °C from the cell: $\text{Ag}, \text{Ag}^+\text{Br}^-(\text{satd.soln}) | \text{AgBr(s)}, \text{Ag}$. The standard potentials are $E_{\text{AgBr,Ag}}^\circ = 0.07 \text{ V}$; $E_{\text{Ag}^+, \text{Ag}}^\circ = 0.80 \text{ V}$. (b) Experimental evidence suggests that H^+ ion in aqueous solution is hydrated to form H_9O_4^+ . In this situation, how can you explain the high mobility of H^+ ion in hydroxylic solvent? [2+2=4]

10. (a) What value of k is predicted by the Arrhenius equation for $T \rightarrow \infty$. Is the result physically reasonable? Explain. [2]
(b) Calculate the room temperature ratio of the rate constant for two reactions that have the same A value but have E_a values that differ by (i) 1 kcal/mol; (ii) 10 kcal/mol [2]
11. Derive expression for variation of equilibrium constant with temperature. How does it explain the effect of temperature on equilibrium as predicted by Le Chatelier's principle. [4]
12. If the vapour pressure of toluene is 60 mm at 40.3 °C and 20 mm at 18.4 °C, calculate (a) the vapour pressure at 25 °C and (b) the heat of vaporization? [2+2=4]
-

13. (a) What are the important features of Li ion battery? With the help of suitable diagram, explain charge/discharge mechanism and its electrochemical equations. [2+4=6]
(b) Derive rate law and expression of equilibrium constant for the below first order reaction opposed by a second order reaction (assuming initial concentration of B & C is zero) [3]
$$A \xrightleftharpoons[k_b]{k_f} B + C$$

(c) The equilibrium constant K_P for a reaction at 600 K and 620 K are 1×10^{-12} and 5×10^{-12} respectively. Considering ΔH to be constant in the above temperature range, calculate ΔH and ΔS for the reaction. [3]
14. (a) (i) Define turnover number in catalysis. (ii) Give Debye-Hückel Onsager equation? Explain clearly what is meant by electrophoretic and asymmetry effect?. [1+2+3=6]
(b) Derive rate law and expression of equilibrium constant for the below second order reaction opposed by a first order reaction (assuming initial concentration of C is zero) [3]
$$A + B \xrightleftharpoons[k_b]{k_f} C$$

(c) Three moles of an ideal gas expands from 5 bar to 1 bar at 298 K. Calculate work done (i) for reversible expansion (ii) for an expansion against a constant external pressure of 1 bar. [3]

—◇—◇—◇—

PART A

(Q1 to Q8: Attempt any six questions. Each Question carries 5 marks.)

1. (i) Write a general method for determining the magnetic properties of complexes. What is the property which is experimentally measured? Why do we need magnetic moment values? (ii) What are the conditions to have orbital contribution in magnetic moment? Which are the *d*-electronic configurations that should have orbital contribution to magnetic moment? [2.5+2.5]

2. Name the following coordination complexes as per the IUPAC recommendations 2005: [5]

(i) $[\text{CoCu}_2\text{Sn}(\text{CH}_3)]\{[\mu-(\text{C}_2\text{H}_3\text{O}_2)]_2(\text{C}_5\text{H}_5)\}$ (ii) $\text{K}_2[\text{Cr}(\text{CN})_2\text{O}_2(\text{O}_2)\text{py}]$

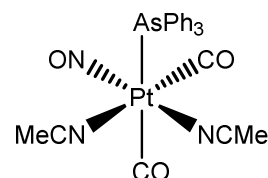
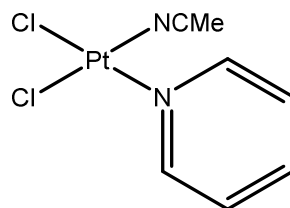
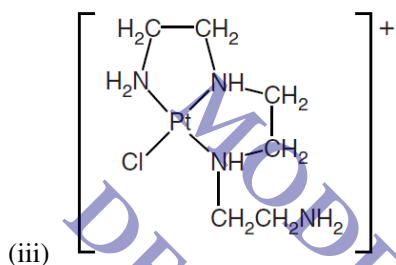

3. (i) Keeping the direction of all three axis same, draw the shapes of various *d*-orbitals. Show that dz^2 orbital is a linear combination of two different orbitals. (ii) Explain how a square planar geometry forms according to crystal field theory? Indicate crystal field splitting in this case and its relation with Δ_o (Δ_o = Octahedral splitting). [2.5+2.5]

4. (i) Draw a comparative diagram for the splitting of *d*-orbitals in Octahedral, trigonal-bipyramidal, square-pyramidal shapes. (ii) How will you distinguish between two limiting five coordinate geometries based on bond angles? (iii) Explain factors contributing to the transition of a high spin to low spin state. [2+2+1]

5. (i) Write the main postulates of CFT. It is observed that crystal field splitting in tetrahedral ligand field is $\sim 0.44\Delta_o$ (Δ_o = Octahedral splitting). Explain why? (ii) Draw and explain how the lattice energy of MF_2 salts ($\text{M} = 3d$ transition series elements) varies along the series? [3+2]

6. (i) State *Jahn-Teller* theorem. Predict the *d*-electron configurations that will exhibit a distorted geometry in their metal complexes. (ii) Explain the electroneutrality principle proposed by Pauling for stability of transition metal complexes. (iii) A $\text{Co}(\text{II})$ complex looks light pink in color while other one looks blue. How will you explain it based on CFT? [2+2+1]

7. (i) What are normal and inverse spinels, explain with examples? How Crystal Field Theory is useful to predict the structure of spinels? (ii) Arrange the following ligands in increasing crystal field strength: NH_3 , bpy, en, SCN^- , N_3^- , H_2O , CO, O^{2-} and OH^- . (iii) What experiments Werner did to propose his theory of coordination compounds? [1.5+1.5+2]

8. (i) A mononuclear $\text{Ni}(\text{II})$ complex exhibit a magnetic moment of 3.12 B.M. How would you justify it? (ii) Draw and explain the shape of a graph between the ionic radii and 3d transition series in M^{2+} state. (iii) What are the three conditions for an element to be an essential element? [2+2+1]

PART B

(Q9 to Q16: Attempt any six questions. Each Question carries 5 marks.)

9. (i) An atom of Thorium-227 decays to produce Lead-211. How many alpha particles are lost? Show all intermediate nucleotides. [2]

(ii) Write the difference between half-life period and average life period. The half-life of the isotope ^{210}Pb is 21 years. What fraction of the original ^{210}Pb atoms will be present after 63 years? [2+1]

10. (i) What is Carbon Dating? A prehistoric site is found to contain charcoal remains with only 6.25 % Carbon-14 compared to fresh wood (100 %). What is the approximate age of the site? [2+1]
 (ii) Positron emission tomography (PET) is a technique that provides information about biochemical processes in the body. Carbon-11 is a positron-emitting radioisotope that is injected into the bloodstream. [2]
 (a) Complete the nuclear equation for the decay of ^{11}C by positron-emission. $^{11}\text{C} \rightarrow ?$
 (b) A sample of ^{11}C had an initial count rate of 640 counts min^{-1} . After 1 hour the count rate had fallen to 80 counts min^{-1} . Calculate the half-life, in minutes of ^{11}C .
11. Answer the following questions. [2+2]
 (i) What quantity of energy would be produced as one atom of plutonium-238 undergoes alpha decay? The nuclide mass of ^{238}Pu is 238.0495 amu and, the nuclide of mass of uranium-234 is 234.0409 amu. The mass of alpha particle is 6.64465×10^{-24} g.
 (ii) A 10.00 g sample of wood from an archaeological site produced 3072 β particles in a 10-hour measurement owing to the presence of carbon-14, while a 10.00 g sample of new wood produced 9216 β particles in the same period of time. The half-life of carbon-14 is 5730 years. How old is the wood from the archaeological site?
12. (i) Give the total metal electron counts, and metal d^n numbers for the following complexes. [1x3=3]
 (a) $\text{Ni}(\text{CO})_4$, (b) $(\text{SMe}_2)\text{AuCl}$, (c) $\text{Ti}(\text{CH}_2\text{Ph})_4$
 (ii) What is Schlenk equilibrium? Explain. [2]
13. (i) Explain the Davies-Green-Mingos rules with examples. [3]
 (ii) Predict which one will be more reactive towards oxidative addition of H_2 for the following complexes. [2]
 (a) $\text{IrCl}(\text{CO})(\text{PPh}_3)_2$ or $[\text{Pt}(\text{Cl}(\text{CO})(\text{PPh}_3)_2)]^+$
 (b) $\text{RhCl}(\text{PPh}_3)_3$ or $\text{RhCl}(\text{CO})(\text{PPh}_3)_2$
14. (i) Which of the following compound should have the highest energy CO stretching frequency? [2]
 (a) $\text{V}(\text{CO})_6$ or $[\text{V}(\text{CO})_6]^-$, (b) $\text{Ni}(\text{CO})_2(\text{PMe}_3)_2$ or $\text{Ni}(\text{CO})_2(\text{PF}_3)_2$
 (ii) What is Petasis reagent? How it is different from Tebbes reagent? [2]
 (iii) What is the role of TMEDA in BuLi reaction? [1]
15. (i) Draw a diagram that illustrates the bonding and back-bonding interactions for a metal-alkene complex. [2]
 (ii) Write a short note on β -hydride elimination. [3]
16. (i) A complex has the empirical formula $\text{Re}(\text{CO})_3\text{Cl}$. How could it attain the 18-electron configuration without requiring any additional ligands? [1]
 (ii) Identify the steps A-D in the following catalytic cycle. [4]

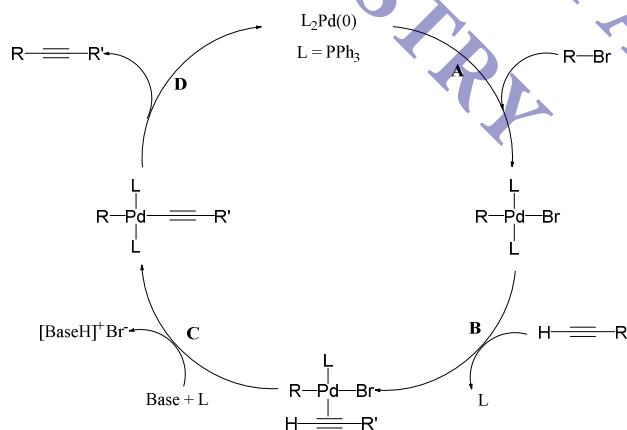



CENTRAL UNIVERSITY OF RAJASTHAN

School of Chemical Sciences & Pharmacy

Department of Chemistry

End of Semester Examination (Semester - VI): Physical Chemistry-III

Course: ICHT - 603

May 04, 2018

Maximum Marks: 60

Time: 10.00 AM - 1.00 PM (3 hrs.)

Note: Questions 1-6 are compulsory. Attempt **any five** from Questions 7-12. Attempt **any one** from Question 13-14.

Section-A

Q. 1 : 1. Assign the point group to the following molecules using the flow chart. (Note: These molecules do not belong to special point group).
(i) PCl_3 (ii) BrF_5 (iii) *fac*- $\text{Mo}(\text{CO})_3(\text{PPh}_3)_3$ (Assume that PPh_3 is spherical) [3]

Q. 2 : Using the atoms, H, F, Cl, Br, (Note: You can use more than one atom of the same type) and the skeleton shown in the below figure, draw the structures of the compounds that belong to the point groups (a) C_1 , (b) C_S , (c) C_{2V} , (d) C_{3V} , and (e) T_d . [3]

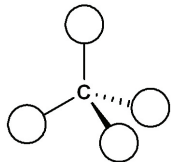

Q. 3 : show that the functions

$$\psi = \left(\frac{1}{2\pi}\right)^{\frac{1}{2}}$$

$$\psi = \left(\frac{1}{\pi}\right)^{\frac{1}{2}} \cos nx$$

$$\psi = \left(\frac{1}{\pi}\right)^{\frac{1}{2}} \sin nx$$

in the interval 0 to 2π are orthogonal; n is an integer. [3]

Q. 4 : If \hat{P} and \hat{Q} are two operators such that $[\hat{P}, \hat{Q}] = 5$, then find out value for $[\hat{P}, \hat{Q}^2]$? [3]

Q. 5 : Define the lattice parameters of various crystal systems and their respective Bravais Lattices? Sketch all the possible axis of symmetry for a cubic lattice with one suitable example. [3]

Q. 6 : Explain *Hardy Schulze Law* with three suitable examples? Comment on *Kraft temperature* and its significance. [3]

Section-B

Q. 7 : Write the possible geometrical isomers of $\text{Fe}(\text{CO})_4(\text{PPh}_3)$ possessing trigonal bipyramidal geometry. [2]

Determine the point group of the isomers (assume PPh_3 as a spherical ligand) using point group flow chart. [2]

Out of the isomers possible, write the group multiplication table for the isomer with lower order of principal axis of rotation. [2]

Q. 8 : (a) What are the properties required for a set of symmetry elements to form a 'group'? [2]

(b) Using the general formula, $\text{MA}_2\text{B}_2\text{C}_2$ (where **M** = Metal; and **A**, **B**, **C** are ligands that are spherical), predict the structures of at least three metal complexes, two of them with D_{2h} , and C_{2v} symmetry and the other being an optically active metal complex.

(i) Draw the structures of the complexes, [3]

(ii) reason for the optical activity of the last complex. [1]

Q. 9 : If a particle is in *two* dimensional box with side *a* and *b*,

a) calculate energy for $n = 1, 2$ and 4 given that $2b = a$

b) comment on first three degenerate states and zero point energy for above *two* dimensional box [3+3=6]

Q. 10 : A particle in an infinite square well, $V(x) = 0$ for $0 < x < L$, $V(x) = \infty$ otherwise. Verify that $\psi = A \sin kx$ and $\psi = A \exp(ikx)$ are eigenfunction of the Hamiltonian operator for the particle. What is the eigenvalue and energy at zero temperature? Draw ψ and probability density for energy level $n=1$ and $n=2$. [6]

Q. 11 : If density of a metal with molar mass 6.941 g mol^{-1} in a F.C.C. unit cell is 0.53 g cm^{-3} . For which plane of the metal, separation can be 350 pm ? Find out planer density for the same and density in x, y and z directions. [2+2+2=6]

Q. 12 : Explain Plank's radiation Law. How does it explain classical concept of distribution of black body radiation? [2+4=6]

Section-C

Q. 13 : (a) (i) Determine the point of *tris(ethylenediamine)cobalt(III)* complex using the flow chart. [1½]
(ii) Show the symmetry elements in the molecule. [1]
(iii) Divide the operations of this point group into classes. [1½]

(b) Find out wave-number of spectral lines for hydrogen atom within the 95 nm to 520 nm range? Show energy band/s and energy diagram. Find out energy gap in eV between any two or more successive bands (if exists). [4+2+2=8]

Q. 14 : (a)(i) Identify and show the symmetry elements of *cis*- $\text{Fe}(\text{CO})_4\text{Cl}_2$, [1½]
(ii) Assign the molecule to a proper point group, [1]
(iii) generate a group multiplication table. [1½]

(b) What is gold number and its significance in colloids? [2]

(c) Draw (220), (202), (002), and (230) crystal planes as per the given x,y,z axes directions in below cubic system. Find out the interplaner distance for crystal plane (202) and (230) (if edge length of the cube is 25 pm). [6]

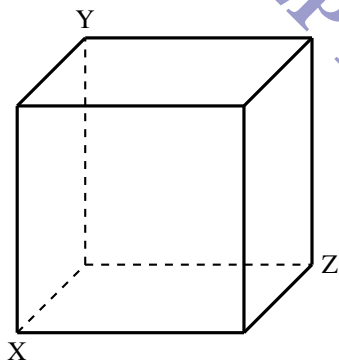

DEPT OF CHEMISTRY QUESTION PAPER

**CENTRAL UNIVERSITY OF RAJASTHAN
DEPARTMENT OF CHEMISTRY**

M.Sc. / Int. M.Sc. B.Ed. / Int. M.Sc. Chemistry; Semester I / VII
End of Semester Examination

(B)CHT-103 / ICHT-703

Stereochemistry and Reaction Mechanism

8th Dec 2017

Time allowed: 3 h

Max marks: 50

Answer ANY 10 questions

(5 marks × 10 = 50)

- (i) With respect to reactivity of cyclohexanes, briefly explain the concept of steric hindrance and steric assistance, taking the example of saponification of *cis* & *trans*-ethyl 4-*tert*-butylcyclohexanecarboxylate and oxidation of *cis* & *trans*-4-*tert*-butylcyclohexanol respectively. (3)
- (ii) Draw the most stable conformation of (1*R*,3*R*)-1-bromo-3-(*tert*-butyl)cyclohexane (2)
- (i) Predict the position of the equilibrium in the cases 'a' and 'b' shown below with a proper justification for each case. (3)

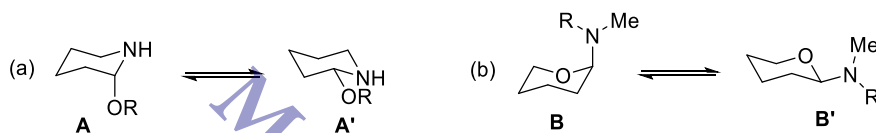

(ii) Compare the formation of kinetic and thermodynamic enolates on the basis of **any two** reaction parameters. (2)

- What do you understand by the Curtin-Hammett principle? Illustrate the concept of Dynamic Kinetic Resolution using this principle with the example of Noyori's asymmetric reduction shown below, clearly outlining the mechanism involved and a reaction coordinate profile.

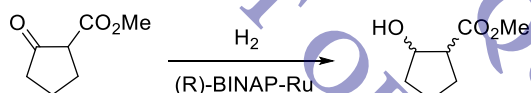

- (i) Determine the ratio of the rate of hydrolysis of *p*-chlorobenzyl bromide and *p*-cyanobenzyl bromide in water. Given: $\rho = -1.31$; $\sigma_p \text{ Cl} = 0.24$; $\sigma_p \text{ CN} = 0.70$. (2.5)
- (ii) The Taft equation for evaluating the steric effect of substituents is given as $\log(k_{\text{subst.}}/k_{\text{std.}}) = \delta E_s$, where δ is the steric sensitivity factor and E_s is the steric substituent constant. Given that E_s values are large and negative for bulky substituents, how can you correlate positive and negative δ values to: (a) the steric effects in the T.S.? (b) the rate of the reaction? (2.5)
- Suggest a suitable mechanism for the reactions shown below based on the given data (the data should be clearly correlated to the mechanism in your justification). (1.5 + 3.5)

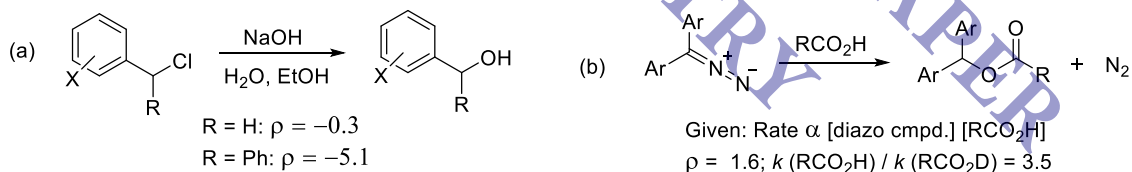

- (i) Outline the difference in mechanism for the two cyclisation reactions 'a' and 'b' given below with a rational justification. (3)

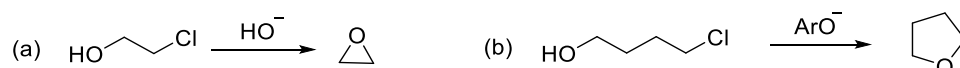

(ii) The hydrolysis of an ortho methyl ester (3 OMe groups on the same carbon) to carboxylic acid proceeds by 'General Acid Catalysis'. Offer a mechanistic/structural justification (using AcOH as catalyst). (2)

- (i) What do you understand by the term "Prochirality"? Differentiate conceptually between sp^2 and sp^3 prochiral carbons. (3)
- (ii) Give an example of a molecule in which a prochiral sp^3 carbon is attached to two H's which are (a) Enantiotopic; (c) Diastereotopic). (2)

8. (i) For the reaction shown below, justify the observed product distribution with proper illustrations / structures and brief details. (4)

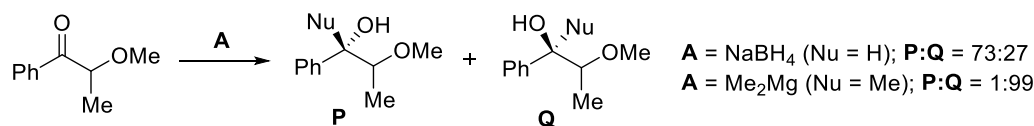

(ii) In the above reaction, which product out of **P** and **Q** would be major if **A** is ZnBH_4 . Offer a very brief justification (structures / illustrations **NOT** required). (1)

9. (i) Outline the mechanism for the reaction given below and identify the unique intermediate **A**. (2)

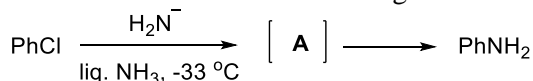

(ii) The mechanism can be proved by **trapping** this intermediate **A** in a reaction with furan. Illustrate this reaction and write the structure of the product. (1.5)

(iii) Identify the product of the reaction given below. (1.5)

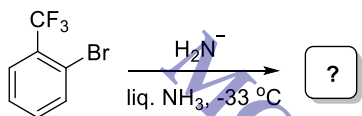

10. (i) The solvolysis of (+)- $\text{PhCH}(\text{Me})\text{Cl}$ in acetone: H_2O (80:20) mixture leads to 98% racemization in the product. On the other hand, when the reaction is carried out in H_2O alone, the extent of racemization in the product is only 80%. Rationalize on the basis of the ion-pair concept in $\text{S}_{\text{N}}1$ reactions. (3)

(ii) Comment on the resolvability / optical activity of the compounds given below. (2)

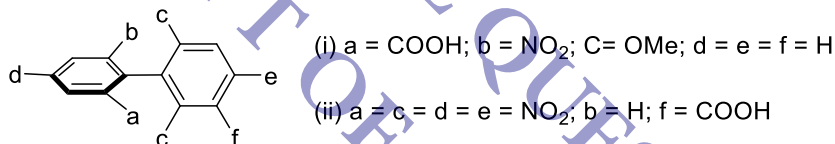

11. (i) What do you understand by a non-classical carbocation? Illustrate both the **classical** and **non-classical** structures for the 2-norbornyl cation. (2.5)

(ii) With suitable examples and illustrations, briefly discuss the stereochemistry that may be observed in allenes and spiranes. (2.5)

12. (i) Propose any 2 fundamentally different mechanisms for the reaction given below. Illustrate how either D labeling or ^{18}O labeling would help to distinguish the mechanisms? (4)

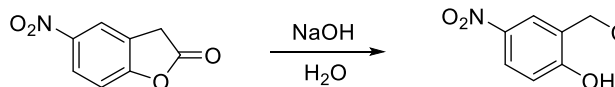

(ii) Comment on whether the above reaction is specific or general base catalysis. (1)

13. (i) Illustrate the following with a suitable example: (1.5)

- (a) Molecule having stereogenic centre(s) but no chiral centres
(b) Molecule having chiral centres but is achiral

(ii) The key step in the asymmetric total synthesis of the natural product (-)-leuconoxine recently reported by Higuchi *et al* (*Org. Lett.* **2015**, *17*, 154) featured the reaction shown below as the key step. Classify this asymmetric induction method and briefly outline its principle. Also mention the advantages offered by this method over a relevant similar method of asymmetric synthesis. (3.5)

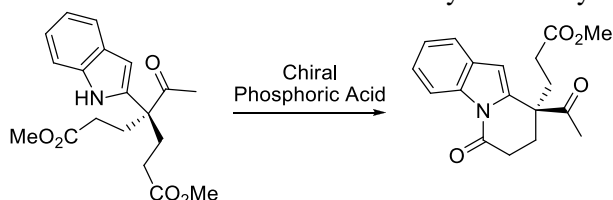

CENTRAL UNIVERSITY OF RAJASTHAN
DEPARTMENT OF CHEMISTRY

M.Sc. / Int. M.Sc. B.Ed. / Int. M.Sc. Chemistry; Semester II / VIII

End of Semester Examination

(B)CHT-202 / ICHT-802

Organic Synthesis - I

9th May 2018

Time allowed: 3 h

Max marks: 60

Answer ANY 10 questions

(6 marks × 10 = 60)

1. (i) Outline a mechanism for the reaction shown below clearly indicating the steps and intermediates involved. What would be the products obtained if H₂O₂ is used for the work-up instead of Me₂S? (4)

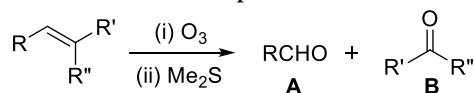

- (ii) Predict the product that would be obtained, **with a suitable mechanism**, upon the treatment of **A** in the question '(i)' above with *m*-CPBA (*meta*-chloroperoxybenzoic acid) (2)

2. Identify the missing reagents / products in the reactions given below and answer the questions that follow them. (2.5 + 3 + 0.5)

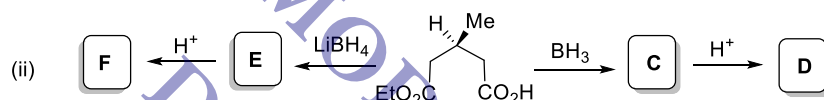
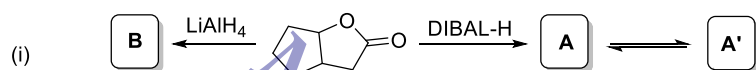

- (iii) In "(ii)" above, what is the stereochemical relationship between **D** and **F**?

3. (i) Sir Robert Woodward used the OsO₄-NaIO₄ protocol for the oxidative cleavage of **A** as an alternative to ozonolysis in his total synthesis of Reserpine. Predict the structure of **B** based on this reaction. Also identify the intermediate product of the reaction, outlining a mechanism for its formation. (3)

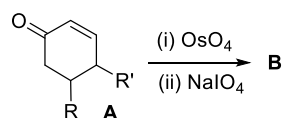

- (ii) Outline the mechanism of Birch reduction with a suitable example each for benzene ring carrying an electron donating and electron withdrawing substituent (3)

4. (i) The product **A** shown in the scheme below **cannot** be made by alkylation of diethyl malonate; rather, it is prepared from the compound **B** by a cross-Claisen condensation. Identify the electrophile that is involved in this transformation and outline a suitable mechanism. (3)

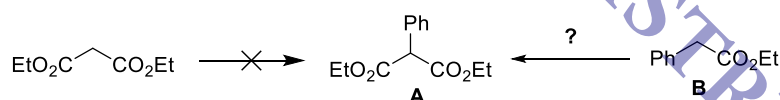

- (ii) Identify the missing reagents / products in the reaction scheme given below: (3)

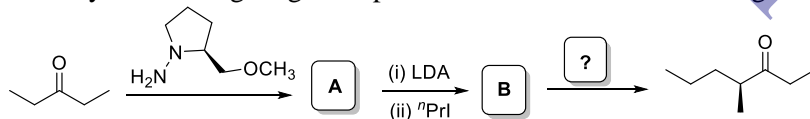

5. (i) Identify **A** & **C** and the conditions required for conversion of **A** to **B** in the reaction given below. (2.5)
(ii) What is the name of this reaction? What is its significance? Compare and contrast this reaction (including the **asymmetric version**) with the Evans aldol reaction. (3.5)

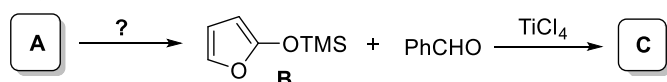

6. (i) Identify **A** & **B** and all the named reactions involved in the reaction scheme given below. (3)
(ii) Outline a mechanism for the conversion of **B** to **C**. (3)

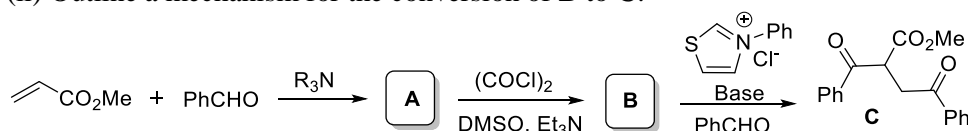

7. (i) Outline a mechanism for the formation of **A** in **Q. No. 6** above. How will you carry out an **asymmetric version** of this reaction? Offer a brief reasoning. (3.5)

(ii) Predict the products and outline a mechanism for the reaction shown below: (2.5)

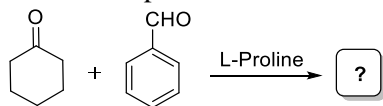

8. (i) In his total synthesis of Shahamin K (**Ref.:** *J. Am. Chem. Soc.* **2001**, 123, 4851), Larry Overman uses a Si-reagent for a key reaction shown below. Predict the product **B** and identify the named reaction. Also suggest a method for the conversion of **B** back to **A**. (2.5)

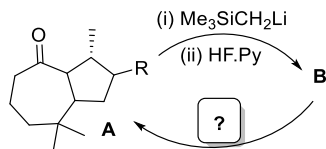

(ii) Provide a suitable mechanism for the reaction given below: (3.5)

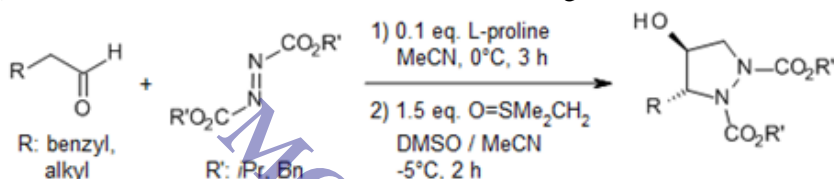

9. (i) What are the 2 major advantages of carrying out the acyloin condensation in the presence of Me_3SiCl ? Outline a mechanism for this reaction taking any general substrate. (3)

(ii) Which carbon atom in allyl and vinyl silanes would be the nucleophilic carbon? Illustrate with appropriate reasoning. Also, which of these two species would be more nucleophilic and why? (3)

10. (i) PPh_3 is used to convert $\text{Pd}(\text{OAc})_2$ to the active catalytic species in a typical Heck reaction. Outline a mechanism for this conversion. (3)

(ii) Predict the products: (3)

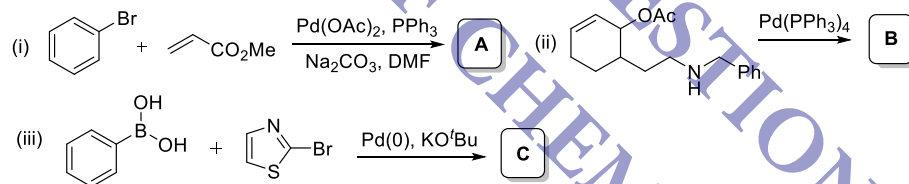

11. Predict the products, identify the name and **outline a suitable mechanism** for the reactions given below:

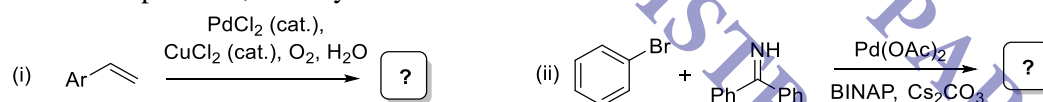

12. Yoshida & co-workers synthesized styrenes using a ring-closing metathesis strategy (**Ref.:** *Org. Lett.* **2008**, 10, 2777) as shown in the scheme below. Answer the questions that follow:

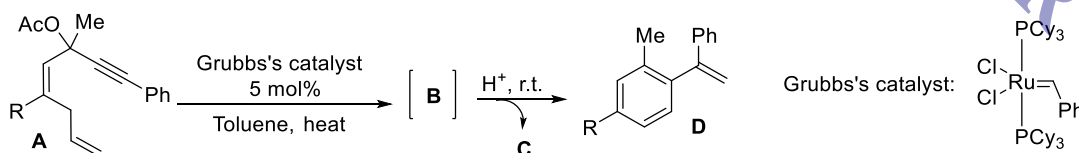

(i) Identify **B** and outline a mechanism for the conversion of **A** to **B** (first 2 catalytic cycles) (4)

(ii) Identify the compound **C**. What would be **C** if 'OAc' is replaced by 'H' in **A** and what reagent can be used for the conversion of **B** to **D** in such a case? (2)

13. Predict the products in the reactions given below and identify the named reaction in each case. (4 + 2)

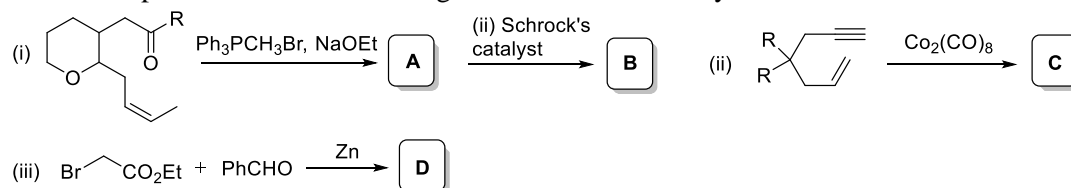

CENTRAL UNIVERSITY OF RAJASTHAN

Department of Chemistry, School of Chemical Sciences and Pharmacy

Integrated M.Sc. (5 Yr), M. Sc. (2 Yr), Integrated M. Sc. B. Ed. (3 Yr); EoSE, **Date:** 08/12/2017 (2-5 pm)

Course Name: Green Chemistry; Course Code: CHT/BCHT-301, ICHT-901

Time: 3 hr

Max. Marks: 50

PART A (Q1 to Q6: All questions are compulsory. Each Question carries 3 marks.)

1. Maleic anhydride may be prepared using two routes: [3]

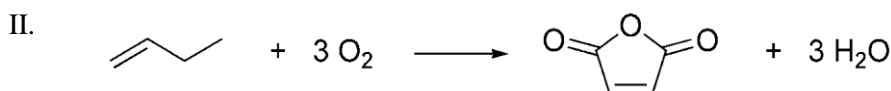
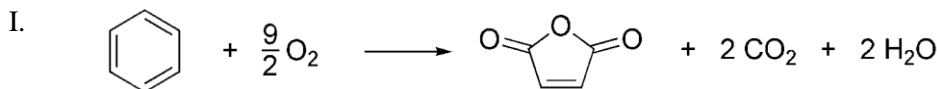

By considering the all green metrics (*at least three*, with calculation), which route would you recommend to industry?

2. Discuss the Green Chemistry principle number **08** and **10** with suitable examples. [1½+1½]
3. Provide green route of synthesizing the following compounds: (a) Ibuprofen, (b) Methyl methacrylate, (c) Citral. [1x3]
4. Write a short note on (a) Passerini reaction, (b) Biopol. [1½+1½]
5. For a given cation the density and viscosity of an ionic liquid depend on the anion. On the basis of this statement arrange the following anions in (i) ascending order of density (ii) ascending order of viscosity
(a) PF₆⁻ (b) BF₄⁻ (c) (CF₃SO₂)₂N⁻
6. What are the differences between homogeneous and heterogeneous catalysis.

PART B (Q7 to Q12: Attempt any FIVE questions. Each Question carries 4 marks.)

7. Predict the product of the following reactions. [1x4=4]

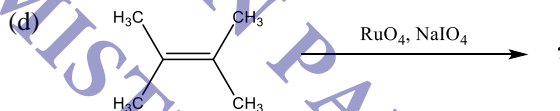
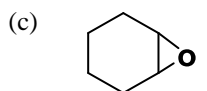
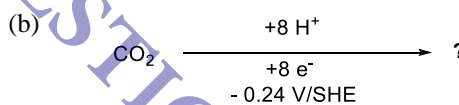
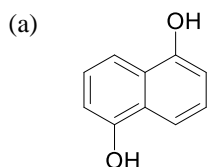

8. (a) In 1990, Haber, F. *et al.* reported the synthesis of aniline from nitrobenzene by electrochemical reduction. Write the intermediates formed from the above reactions. [2]
- (b) Ruthenium catalyzed *transfer hydrogenation reaction* is an alternative greener process for the reduction reaction. Write down the transformation. Why this process termed as a greener method? Explain. [2]
9. Condensation reactions are being applied to the preparation of unsaturated polyesters from the biobased feedstock 5-hydroxymethylfurfural (HMF) in presence of an organocatalyst developed by Prof. Eugene Y.-X. Chen (2015 academic award winner). Write the structure of organocatalyst and discuss the chemical transformation. Show the mechanism of the condensation reaction. [1+1+2]
10. (a) Define Risk and Hazard. [2]
- (b) “Metathesis reaction is a green chemical process”. Elaborate this statement using principles of green chemistry. [2]
11. Draw the chemical structures for the following ionic liquids. [1x4 = 4]
- (i) 1-Methylimidazolium chloride (ii) 1-Butyl-3-methylimidazolium thiocyanate
- (iii) 1-Ethyl-3-methylimidazolium hydrogen sulfate (iv) 1-Butyl-3-methylimidazolium methanesulfonate
12. Define super critical fluids with the help of phase diagram. Write any two applications of scCO₂ and scH₂O.

PART C (Answer ANY ONE of the following questions; Q. No. 13 or 14)

13. Answer the following:

(i). Predict the product in the following reaction, and suggest the mechanism of their formation. [4]

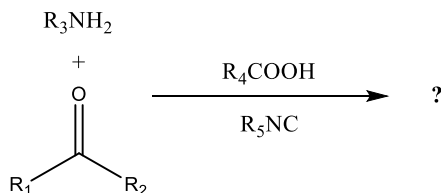

(ii) Write down the basic principle of microwave heating. Discuss the effect of solvent in microwave heating. [3+1]

(iii) Enzymes are classified in to six functional types. List them all with an example and its catalytic functions. [4]

OR

14. Answer the following:

(i) Calculate the atom economy and Carbon efficiency of the following reaction. [4]

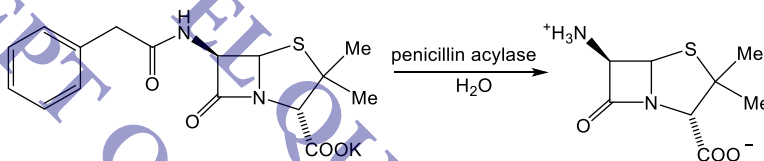

(ii) (a) RuO_4 is used as a catalyst for the oxidative cleavage of olefins in presence of NaIO_4 . Draw the catalytic cycle. [2]

(b) What is Risk Assessment? Discuss all the steps involved for the risk reduction measures. [2]

(iii) Explain Raston's synthesis of complex pyridines with appropriate mechanism. [4]

CENTRAL UNIVERSITY OF RAJASTHAN

Department of Chemistry, School of Chemical Sciences and Pharmacy

Integrated M.Sc. (5 Yr), M. Sc. (2 Yr), Integrated M. Sc. B. Ed. (3 Yr); EoSE, **Date:** 06/12/2017

Course Name: Photochemistry, Pericyclic Reactions & Carbocyclic Ring Systems;

Time: 3 hr

Course Code: CHT/BCHT-302, ICHT-902

Max. Marks: 50

PART A (Q1 to Q6: All questions are compulsory. Each Question carries 3 marks.)

1. (a) What product is formed when triene **P** undergoes thermal electrocyclic ring closure? (b) What product is formed when triene **P** undergoes photochemical ring closure? Label each process as conrotatory and disrotatory. [2]

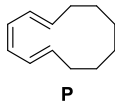

- (c) Draw arrow pushing mechanism of the following reaction. [1]

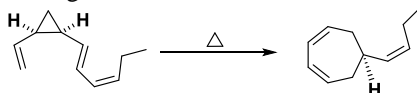

2. (a) The following method has been used for the synthesis of vitamin D. Identify the structure of intermediate **A**. [2]

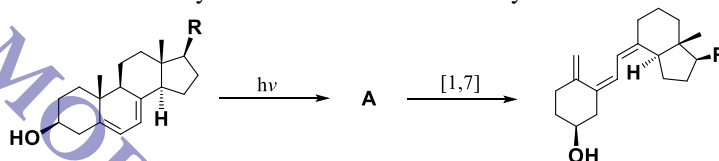

- (b) Identify **A** and **B** in the following reaction sequence. Label the each process as conrotatory or disrotatory. [1]

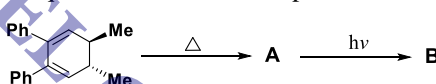

3. Sketch the π -molecular orbitals of 2,4-pentadienyl system. Also draw nodal points in molecular orbitals. Show electron occupancy in its carbocation, free radical and carbanion. [3]
4. What are the types of excitations given by organic compounds? Provide an example for each type of excitation. [3]
5. Define "photosensitization" and "energy cascade". [3]
6. Irradiation of alkyl nitrite yields an alcohol–oxime. Write a suitable mechanism for this transformation. [3]

PART B (Q7 to Q12: Attempt any FIVE questions. Each Question carries 4 marks.)

7. Predict the product of the following reactions with stereochemistry. [1x4=4]

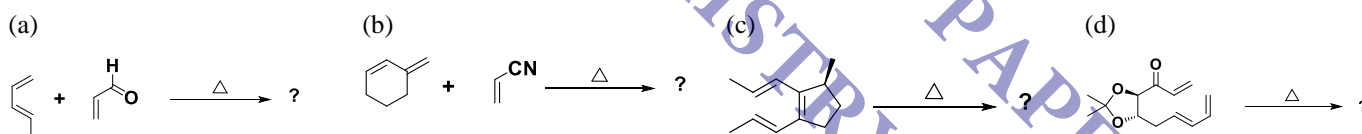

8. (a) Show the mechanism of the following reaction. [2]

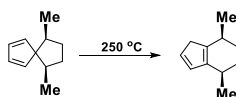

- (b) The following bicyclic alkene **B** can be prepared by thermal electrocyclic ring closure from cyclodecadiene **A₁** or by photochemical electrocyclic ring closure from cyclodecadiene **A₂**. Draw the structures of **A₁** and **A₂**, and indicate the stereochemistry of the process by which each reaction occurs. [1+1]

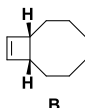

9. (a) Write the mechanism of the following reaction. [2]

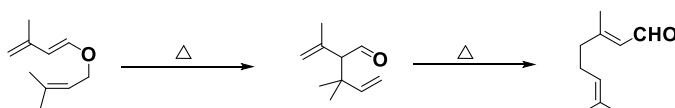

(b) The reaction of hydroxylamine and benzaldehyde results in the formation of a reactive intermediate [A]. Intermediate [A] subsequently undergoes a reaction with styrene to give the product [B]. Identify the structure of [A], and provide a mechanism for the reaction of [A] with styrene to form [B]. [2]

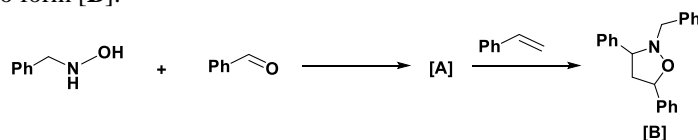

10. (a) Predict the product for the given transformations with detailed mechanism. [2]

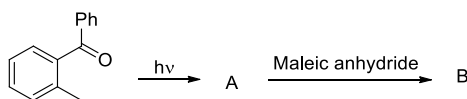

(b) Propose the mechanism for the photo reduction reaction (depicted below). [2]

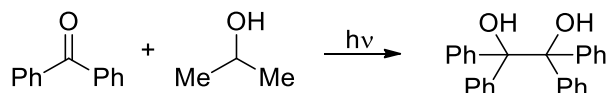

11. Explain Hunsdiecker reaction and autoxidation with a suitable example. [4]

12. Propose the mechanism and/or product for the following transformations [2+2]

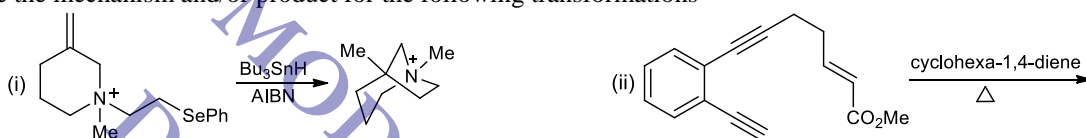

PART C (Answer ANY ONE of the following questions; Q. No. 13 or 14)

13. Answer the following:

- Irradiation of benzene at 254 nm light under nitrogen conditions yields fulvene. Outline the mechanism for this reaction. [3]
- Define photostationary state. Discuss about the reasons behind cis-trans isomerization of stilbene in direct irradiation. [3]
- Draw the chemical structures of persistent free radicals (a) Perchlorotriptyl; (b) Galvinoxyl; (c) BHT radical. [3]
- Answer the following question for π -molecular orbitals of 1,3,5-hexatriene. [1x3=3]
 - Which are the bonding orbitals and antibonding orbitals?
 - Which orbitals are HOMO and LUMO in ground state and excited state?
 - Which orbitals are symmetric and asymmetric with respect to mirror plane and C_2 axis?

OR

14. Answer the following:

- Irradiation of *o*-Xylene yields mixture of *m*- and *p*-Xylene. Propose a suitable mechanism for this transformation. [3]
- Write all the steps involved in the Barton–McCombie reaction with a suitable example. [3]
- Predict the product for the given transformations with detailed mechanism. [3]

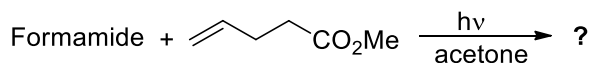

- What is Claisen rearrangement? Write down the selection rules for sigmatropic rearrangement. [1+2]

Time: 3hr

Max. Marks: 50

Part A

All questions are compulsory. Each question carries 3 marks

- 1.(i) What are chemically possible models for O₂ binding to iron centre in hemoglobin. (ii) What are the functions of globin in heme oxygenation? **(1.5 + 1.5)**
2. Write the active site structure of arene cis-dihydroxylating oxygenases with all its components. Write the catalytic cycle of the enzyme clearly mentioning oxidation states. **(3)**
3. Draw the active site structure of catalase enzyme and propose a suitable mechanism for H₂O₂ decomposition by its action.
- 4.(i) Draw the oxy- and de-oxy form of oxygen transfer protein hemocyanin. (ii) Write the mechanism of allylic peroxidation catalyzed by lipoxygenase. **(1.5 + 1.5)**
5. (i) What are the main criteria for the selection of certain essential elements in biology? (ii) Despite the high abundance of Si, Al, and Ti, why are they not utilized biologically? (iii) Why has cobalt given an essential role in cobalamins despite its very low availability? **(1+1+1)**
6. Write a short note on metal chelation therapy. Draw the structure of following: (i) Deferoxamine; (ii) Deferasirox; (iii) BAL; (iv) penicillamine. **(1+2)**

Part B

Answer any FIVE questions. Each question carries 4 marks

7. i) What is Wilson disease? Discuss in brief with cause, mechanism and possible treatments. (ii) Why a singlet dioxygen pathway or a free radical pathway should not be a favorable pathway for dioxygen reactions in biological systems. **(2 + 2)**
8. Although dioxygen is a powerful oxidant still direct reactions of dioxygen with organic substrate are very slow. Why? (ii) What are the various steps possible in the four electron dioxygen reduction to water, which step is least favorable and why? **(2+2)**
9. Write a brief note on (i) deoxy- and oxy-form of hemerythrin. (ii) Isomer shift and quadrupole splitting in Mossbauer spectroscopy. (iv) classification of metallobiomolecules based on their functions **(1+1+2)**
10. (i) Draw the EPR spectrum a Cu(II) complex having two axial coordinating ligand as pyridine ($I_{Cu} = 3/2$; $I_N = 1$). (ii) Write the principle for using a "contrast agent" in magnetic resonance imaging with the structures for two MRI contrast agents. **(2+2)**
11. (i) Discuss the various active oxygen species to carry out the monooxygenation of substrate in Cytochrome-P450 class of enzyme? (ii) Write a short note on symptoms, cause, and possible treatments for Alzheimer's disease. **(2+2)**

12. (i) Discuss the various spectroscopic and other techniques applied to come to a conclusion for the active site structure determination for an intradiol dioxygenase. (ii) Comment on the basic principle of EPR spectroscopy. (2+2)

Part C

Answer any ONE question (Q. No. 13 OR 14).

13. (i) Which imaging technique is more sensitive between PET and SPECT and why? Why ^{64}Cu should be beneficial over ^{18}F as radiotracer in PET imaging? . (2+1)
- (ii) Discuss in detail the various allosteric effectors related to regulation of Hemoglobin activity. (3)
- (iii) Write the structure of Cu-Zn superoxide dismutase and explain its mechanism of action. (3)
- (iv) What are the cause, symptoms, mechanism and treatments for mercury poisoning? (3)

OR

14. (i) Define the conditions of essentiality for an element. Draw a dose response curve for an essential element. (3)
- (ii) Write a brief note on the principle of CT-SCAN, scintigraphy and SPECT techniques. Write structure of two metal complexes frequently used in SPECT. (3)
- (iii) (i) What are the functions of carbonic anhydrase? Give the proposed mechanism of the peptide hydrolysis by the carboxypeptidase-A. (1+2)
- (ii) Draw the active site structures for both intradiol and extradiol dioxygenases and draw the products formed by oxidation of catechol by different dioxygenases. Write the proposed mechanism only for intradiol dioxygenase. (3)

CENTRAL UNIVERSITY OF RAJASTHAN
DEPARTMENT OF CHEMISTRY
 Int. M.Sc. B.Ed. Chemistry; Semester IV

End of Semester Examination

BCHT-402

Natural Products

4th May 2018

Time allowed: 3 h

Max marks: 60

Section A (Answer ANY 5)

(5 marks × 5 = 25 marks)

1. (i) Assign each of the following natural products to a general class and subsequently to a more specific class (for eg. Terpene; sesquiterpene): (1)

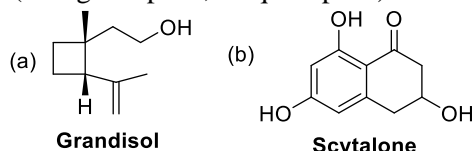

- (ii) The biosynthesis of terpenes sometimes involves coupling of pyrophosphate units in a head-to-head fashion to generate a cyclopropane intermediate. Based on this, suggest a biosynthetic route to the monoterpenes chrysanthemic acid and artemesia ketone from two units of dimethyl allyl pyrophosphate (DMAPP) (shown below). (4)



2. Identify the missing steps / reactants / reagents / products in the **biosynthesis** of cocaine and adrenaline given below: (5)

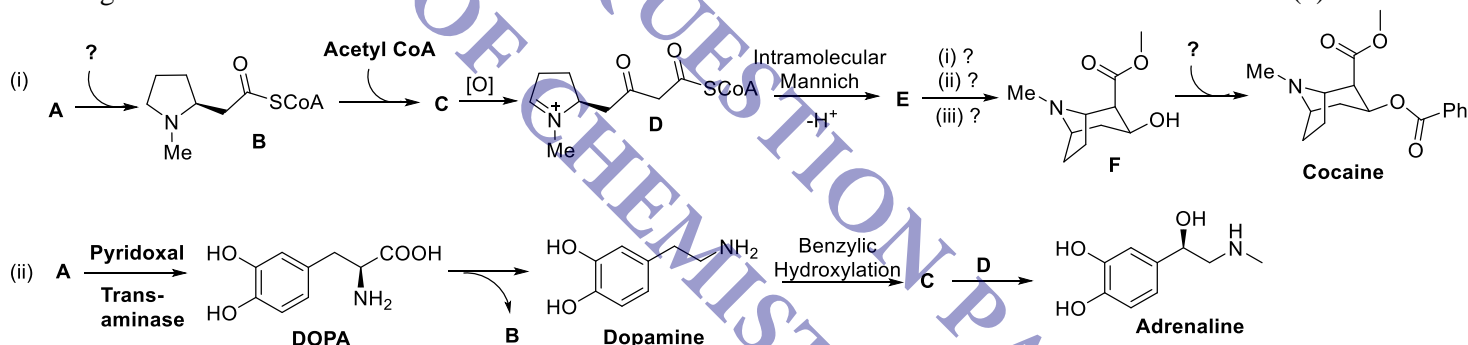

3. (i) Outline the steps – with the structures of the intermediates – for the conversion of **A** to **B** and predict the structure of **C** in a sequence from Woodward's synthesis of reserpine shown below: (2.5)

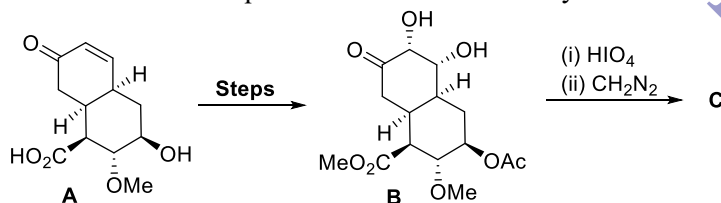

- (ii) For the scheme given below: (a) outline a mechanism for the conversion of **A** to intermediate **B** and classify the type of reaction; (b) identify the missing intermediates / reagents (2.5)

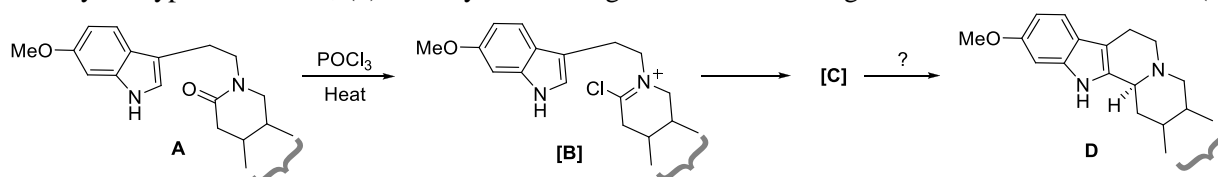

4. (i) In the total synthesis of Reserpine Sir Robert Woodward used an ingenious maneuver to bring about the epimerization of the C-D ring junction of the isoreserpate compound **A** (structure shown below). Illustrate the strategy with a brief justification. (3.5)

Hint: Draw the compound **A** (and intermediates involved) in chair conformation to illustrate your answer.

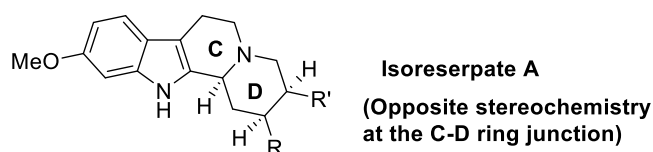

- (ii) Outline suitable disconnections, with intermediate structures, for the retrosynthetic scheme given below: (1.5)

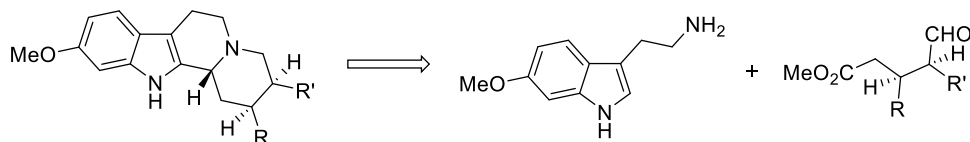

5. Answer the questions that follow based on the reaction sequence from Overman's total synthesis of strychnine shown below:

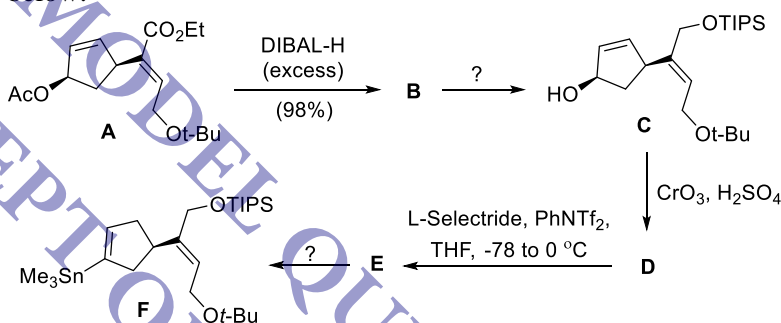

- (a) Identify the missing products **B**, **D** and **E**. (3)
 (b) What are the reagents required for the transformation of **B** to **C** and **E** to **F**? (2)
6. (i) Name the reaction shown below and outline a suitable mechanism: (3)

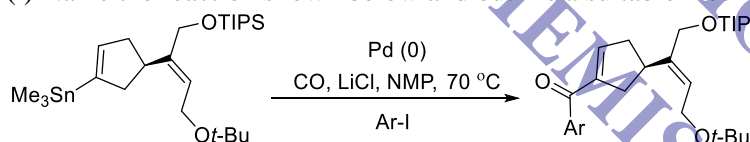

- (ii) Overman's enantioselective total synthesis of strychnine generates asymmetry right at the outset with the reaction shown below. What strategy of asymmetric induction is being used? Briefly outline the **fundamental principle of this strategy**. (2)

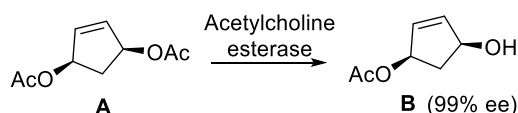

7. Answer the questions that follow the scheme shown below:

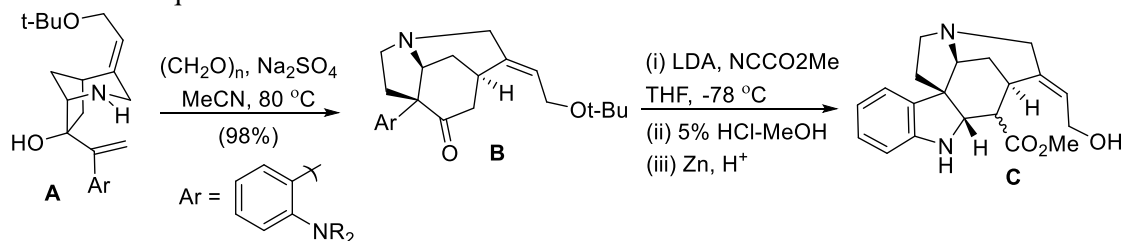

- (a) Outline a mechanism for the transformation of **A** to **B**, clearly showing the intermediates. Identify the named reactions involved. (3)
 (b) How would you elaborate compound **C** to the desired 7-membered lactol present in strychnine using the handle of the hydroxy and ester groups? (2)

Section B (Answer ANY 7)

(5 marks × 7 = 35 marks)

8. Write the retrosynthetic analysis and synthetic strategy to the following target materials. (3 + 2)

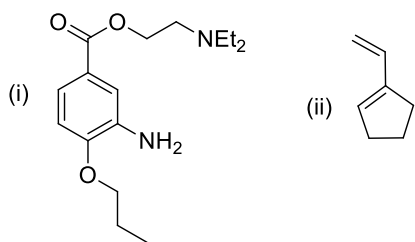

9. Outline the retrosynthetic analysis and synthetic strategy (with detailed mechanism) to 2-veratryltryptamine by using the following strategies

(i) Fischer indole synthesis (ii) Mannich reaction (iii) S_N2 (iv) Reduction

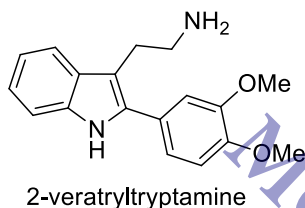

10. Write the reaction conditions (i-vii) in the synthetic scheme shown below:

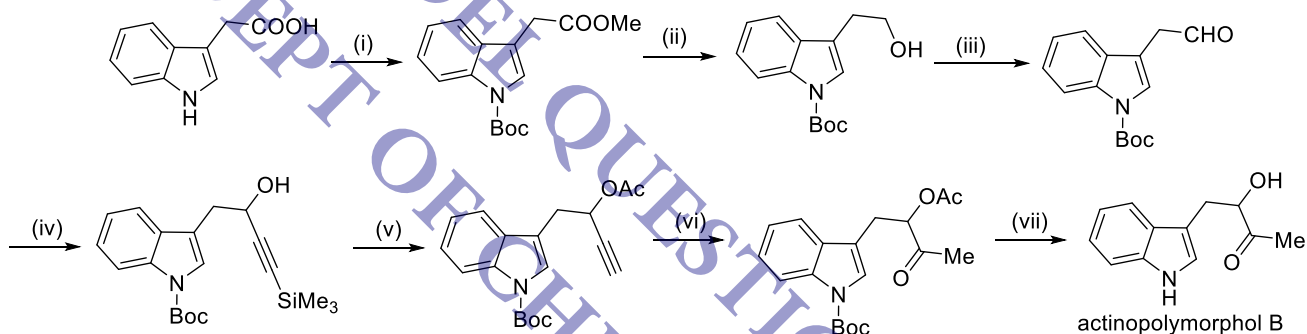

11. Propose the mechanism for the transformations given below:

(2.5 × 2)

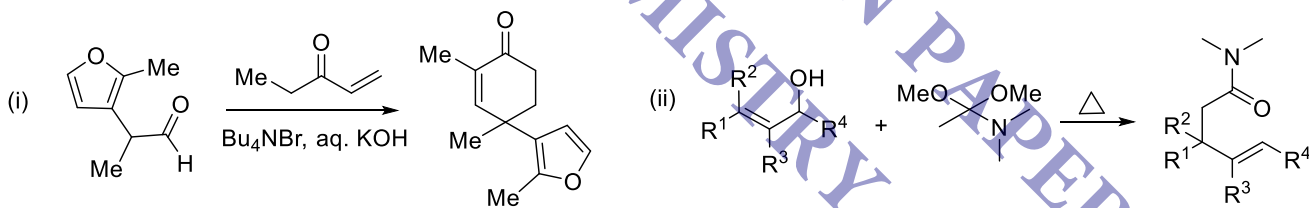

12. How could you construct C-C bond formation by using the organo reagents of Boron, Silicon, Zinc, Copper, Magnesium. Provide an example for each. (1 × 5)

13. Identify A, B, C, (i) and (ii) in the following transformation. (1 × 5)

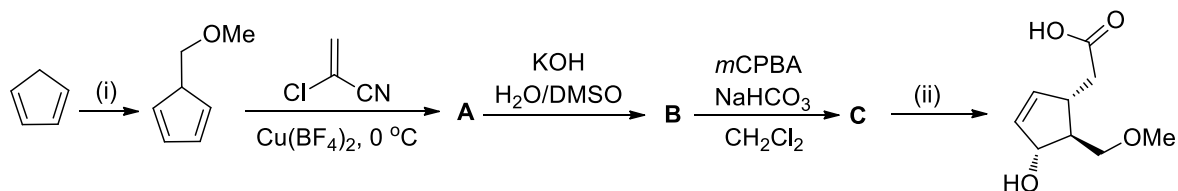

CENTRAL UNIVERSITY OF RAJASTHAN
DEPARTMENT OF CHEMISTRY
 Int. M.Sc. B.Ed. Chemistry (Batch-2014); Semester IV

End of Semester Examination

BCHT-403

Physical Organic Chemistry

24th Apr 2017

Time allowed: 3 h

Max marks: 50

Answer **ANY 10** Questions

(5 marks × 10 = 50)

1. (i) Compare the energies of 1,4-*cis*- and 1,4-*trans*-dimethylcyclohexane based on conformational analysis and deduce which would be the more stable diastereomer. (3.5)
 (ii) Draw the most stable conformation of (1*S*,3*S*)-1-bromo-3-(*tert*-butyl)cyclohexane (1.5)

2. (i) Draw the most stable conformation of the compound shown in 'a' below with appropriate reasoning. (2)
 (ii) Predict the position of the equilibrium established by acetal cleavage between the diastereomers **B** and **B'** by comparing their most stable conformations. (3)

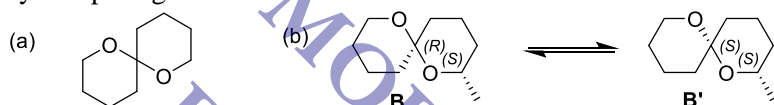

Hint: Heteroatom hyperconjugation

3. (i) In the compounds shown below, justify why the rate of oxidation of **A** is faster than that of **B**. How would you compare the rate of oxidation of **C** with **A** and **B**? (3)

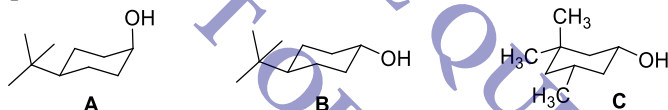

- (ii) Give 1 example each for "steric approach control" and "product development control" with respect to reactivity in cyclohexanes. (2)

4. (i) For a given electrophile RCO^+ , what would be the correct order of nucleophilicity of the following species: F^- , I^- , ArO^- , MeO^- . Justify your answer based on the HSAB principle: (2.5)

- (ii) Given that SCN^- is an ambident nucleophile, predict the product for each of the reactions shown below. Offer a brief justification. (2.5)



5. (i) Comment on the acidity of **A** and basicity of **B** shown below based on steric effects: (3)

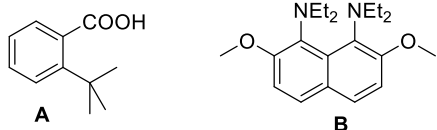

- (ii) Compare the basicity of $\text{HC}\equiv\text{C}^-$, $\text{H}_2\text{C}=\text{CH}^-$ and $\text{H}_3\text{C}-\text{CH}_2^-$ using hybridization as the parameter. Based on this, predict the position of protonation in a compound bearing both hydroxy and carbonyl groups. (2)

6. (i) Hammond postulated that the transition state of a reaction would resemble the higher energy species more closely. Based on this, draw the reaction coordinate profiles of an exothermic and endothermic process and mark the transition states as "early" or "late". (3)

- (ii) Predict whether the reaction shown below would involve an "early" or "late" transition state. (2)

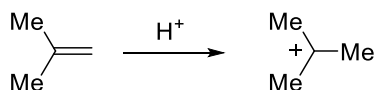

7. (i) How can the enthalpy of activation ΔH^\ddagger and entropy of activation ΔS^\ddagger help in determining the concerted / non-concerted nature of a reaction? Illustrate with suitable examples. (3)

- (ii) The reaction shown below has a ΔS^\ddagger of $-6.6 \text{ cal mol}^{-1} \text{ K}^{-1}$. How can this be justified? (2)

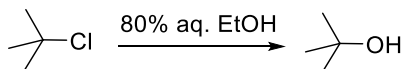

8. (i) What do you understand by the Curtin-Hammett principle? Illustrate the concept of Dynamic Kinetic Resolution using this principle with the example of Noyori's asymmetric reduction shown below, clearly outlining the mechanism involved and a reaction coordinate profile. (5)

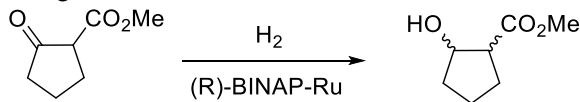

9. (i) Determine the ratio of the rate of hydrolysis of *p*-chlorobenzyl bromide and *p*-cyanobenzyl bromide in water. Given: $\rho = -1.31$; $\sigma_p \text{ Cl} = 0.24$; $\sigma_p \text{ CN} = 0.70$. (2)
 (ii) The Taft equation for evaluating the steric effect of substituents is given as $\log(k_{\text{subst.}}/k_{\text{std.}}) = \delta E_s$, where δ is the steric sensitivity factor and E_s is the steric substituent constant. Given that E_s values are large and negative for bulky substituents, how can you correlate positive and negative δ values to: (a) the steric effects in the T.S.? (b) the rate of the reaction? (c) steric hindrance and steric assistance? (3)

10. (i) The Cannizzaro reaction is a classical disproportionation reaction that takes place in strongly basic solution as given below:



Based on the data given below, suggest a suitable mechanism with appropriate justification. (4)

- a) When the reaction is carried out in D_2O , the benzyl alcohol contains no D in the methylene group.
 b) When the reaction is carried out in H_2^{18}O , both benzyl alcohol and sodium benzoate contain ^{18}O .
 c) The rate = $k [\text{PhCHO}]^2 [\text{HO}^-]$
 d) Hammett ρ value correlation for substituted benzaldehydes = +3.76
 e) $k(\text{D}_2\text{O}) / k(\text{H}_2\text{O}) = 1.90$
 (ii) Comment on whether the above reaction is specific or general base catalysis. (1)
11. (i) Outline the important features of specific acid catalysis and give a suitable example. Predict, with proper reasoning, whether the reaction shown below would proceed via general or specific acid catalysis. (4)

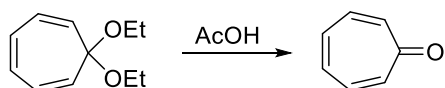

- (ii) Why is an inverse solvent isotope effect observed in specific acid catalysis? (1)

12. Outline the concept of Huckel and Mobius aromaticity based on the formation of [12] annulene shown below (clearly bring out the differences with regards to the rules of the two types). What are the two important parameters used to quantify aromaticity of a transition state in such reactions? (5)

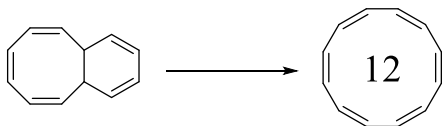

13. (i) Illustrate the structure of the missing products: (3)

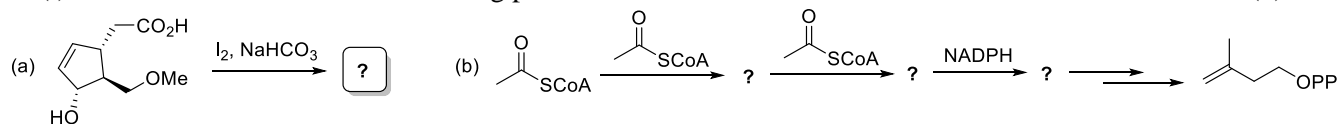

- (ii) Isopentenyl pyrophosphate depicted in "(b)" was recognized as a key intermediate in the biosynthesis of terpenes by isotopic labeling studies. So, if the acetyl CoA is radioactively labeled at C-2, predict the positions of the labels in isopentenyl pyrophosphate using a '*'. (2)